

# SAF BIGFOOT CLASSIC

NEW TRAILER  
SUPPORT SYSTEM:  
ROBUST  
ECONOMICAL  
FAST



# NEW!

The SAF BIGFOOT Landing Gear were originally developed for the most demanding trailer applications in the world – USA and Canada. They have proven their worth over millions of miles under the toughest of conditions - on the desert highways in the western USA and the brutal winters of Canada's far north.

This trailer support system is now available in Europe as the SAF BIGFOOT CLASSIC – an especially economic, robust and reliable solution making it perfect for just about any trailer.

**SAF BIGFOOT Landing Gear meet the following requirements:**

- AAR – Association of American Railroad
- TTMA – Truck Trailer Manufacturers Association

**In Germany please observe:**

- TÜV and German Road Traffic Registration Regulations.
- The Landing Gear should always be operated in accordance with the instructions for the semi-trailer.

**Patented CONSTANT MESH GEAR (CMG)**

- to change gear, the gear does not need to be shifted, just engage and dis-engage high or low gear with the journal on the drive shaft
- that makes gear changes easier, safer and more convenient regardless of the grease level or external temperature (such as in winter)

**SAF**   
SAF-HOLLAND Group

## BIGFOOT CLASSIC TRAILER SUPPORT SYSTEM

**72,000 kg static load**  
**23,000 kg lifting capacity**





#### Patented CONSTANT MESH GEAR (CMG)

- external gearbox enables easy inspection when necessary
- special coating provides long-term protection against environmental factors and stone chipping
- high degree of operational reliability with its multi-range grease (-50° to +150° C)
- high gear 1.75 crank turns per cm
- low gear 13.5 crank turns per cm

#### Patented SPEED CRANK (SC)

- automatic coupling when you lift the crank
- easy and reliable one-hand operation
- especially easy to handle in comparison to conventional cranks

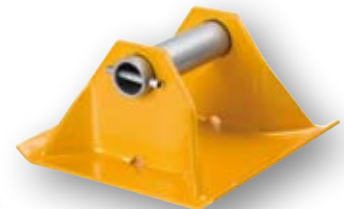

Sand Shoe



Rocking Foot



Wheel

Compensating Foot

# TABLE OF PARTS

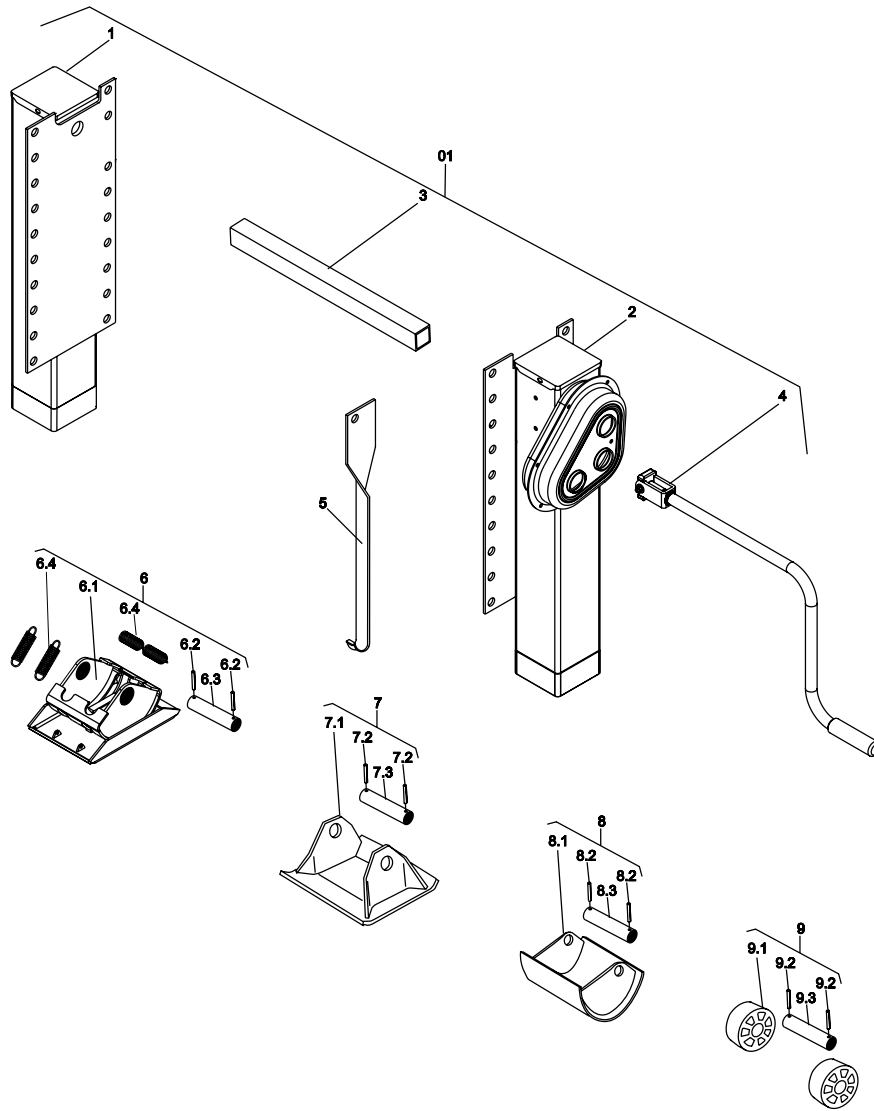

Dimensions	Sand Shoe	Compensating Foot	Rocking Foot	Wheel
Mounting height [A]	800 mm	818 mm	805 mm	800 mm

Position	Product	Sand Shoe	Compensating Foot	Rocking Foot	Wheel
01	Set*	3 427 0182 00	3 427 0179 00	3 427 0188 00	3 427 0191 00
	Leg gearside	3 427 0183 00	3 427 0180 00	3 427 0189 00	3 427 0192 00
	Leg w/o gear	3 427 0184 00	3 427 0181 00	3 427 0190 00	3 427 0193 00
2	Leg w/o foot (gearside)	4 434 2203 00	4 434 2201 00	4 434 2203 00	4 434 2203 00
1	Leg w/o foot	4 434 2204 00	4 434 2202 00	4 434 2204 00	4 434 2204 00
4	Crank 500 mm	3 427 0195 00			
4	Crank 350 mm	3 427 0194 00			
5	Crank holder	3 427 0198 00			
3	Cross drive shaft 1500 mm	XA-E-1910			
3	Cross drive shaft 1800 mm	XA-E-1910-1800			
6-9	Sparepart kit including foot, mounting parts and accessories	3 434 2002 00	3 434 2001 00	3 434 2003 00	3 434 2004 00

**\*Please note:**

Set = pair of right and left landing legs.

The cross drive shaft, speed crank (SC), and crank holder are not included and have to be ordered separately.





SAF's history begins in 1881 in a village forge in Germany with the invention of a new plough. The family business soon starts building steel axles for agricultural vehicles, and under the name Otto Sauer Achsenfabrik (SAF) develops into one of the leading manufacturers of trailer axles and suspension systems in Europe.

A safety coupling between plough and horse team can be found at the beginning of Holland's history. The Safety Release Clevis Company is founded in South Dakota, USA, in 1910. After its move to Holland, Michigan, the company emerges as one of the largest supplier companies to the commercial vehicles industry under the name The Holland Hitch Company.

The merger of the two companies to form SAF-HOLLAND in 2006 creates one of the leading global suppliers of high-quality components and services for the commercial vehicle industry. Alongside axle and suspension systems for trailers and semi-trailers, the product range also includes kingpins and landing gear as well as fifth wheels for tractors, air suspensions, coupling products and numerous other components for buses and trucks.

Today SAF-HOLLAND is represented on all continents and distributes its products and services worldwide under the brand names SAF and HOLLAND. It can boast of an extensive distribution network with global service and dealer locations.

## HIGH QUALITY COMPONENTS FOR THE COMMERCIAL VEHICLE INDUSTRY



EUROPE · NORTH AMERICA · SOUTH AMERICA · AFRICA · ASIA · AUSTRALIA

**SAF-HOLLAND GmbH**

Hauptstraße 26 · 63856 Bessenbach · Germany · Tel +49 6095 301-0

[www.safholland.com](http://www.safholland.com)

